

# ECA Comprehensive Guide to Harmonised Cable Colours

BS 7671: 2001  
Amendment No 2

March 2004

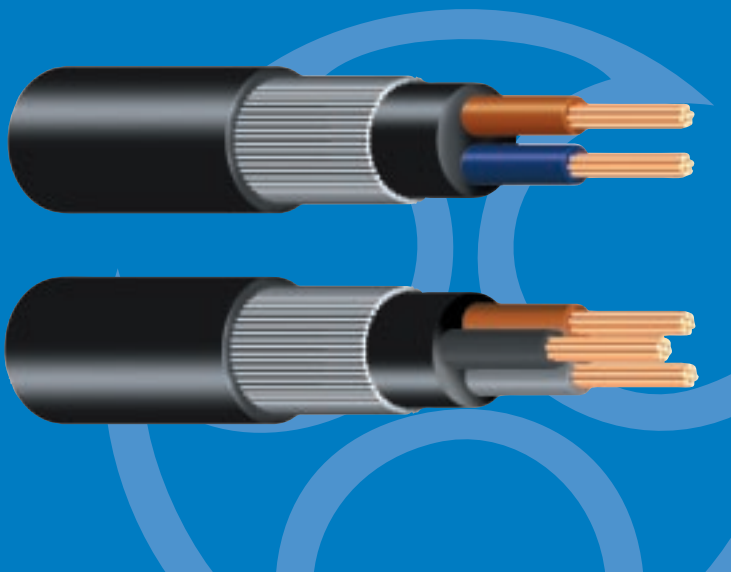

INCLUDING - Existing & Harmonised Cable Identification Wall Chart



Representing the best in electrical  
engineering and building services

# ECA Comprehensive Guide to Harmonised Cable Colours

## BS 7671: 2001 Amendment No 2

March 2004

### WHY CHANGE CABLE COLOURS?

#### INTRODUCTION

Some parts of the IEE Wiring Regulations (Requirements for Electrical Installations) BS 7671 have been based (harmonised) on a common European standard document for some time.

The UK agreed to harmonise with CENELEC (the European Committee for Electrical Standardisation) for Cable Colours for fixed electrical wiring back in 1981.

The agreement was to have blue as the Neutral conductor colour and brown as one of the Phase conductor colours.

Since this agreement, the new single-phase colours of brown and blue have been used in electrical appliance flexible cables and lighting products for some 25 years.

Since then, the UK was virtually the only CENELEC country not using a combination of browns and/or blacks for phase conductors. Therefore, in order to achieve harmonisation, the red and yellow phase conductors were not an option.

International (IEC) harmonisation of cable colours was not considered a viable option and thus this harmonisation applies to Europe only.

#### HOW HARMONISATION WAS ACHIEVED

The standard for multicore fixed wiring cable colours (document HD 308) was harmonised in 2001.

Also, the man machine interface identification standard was agreed in 2000 (BS EN 60446:2000) and work started in CENELEC

and the UK to harmonise installation regulations. The BS 7671 Committee agreed to amend BS 7671 to reflect HD 308 and BS EN 60446 and also revise DC colours to suit.

This guide gives a full explanation of the colour Amendment No.2 to BS 7671:2001 (31st March 2004) for both a.c. and d.c. colours as well as providing pictorial representations of Regulations and a 'Question and Answer' section.

#### TERMINOLOGY

Throughout this document "new" cable colours introduced in Amendment No2 are known as "harmonised" and the old (i.e. red, yellow, blue) colours are known as "pre-harmonised".

The BS 7671 amendment introducing harmonised colours is

**BS 7671:2001  
Requirements for Electrical Installations  
Amendment No.2 March 2004**

*(it was published on 31st March 2004)*

#### TIMING OF IMPLEMENTATION

As shown in the diagram below, harmonised colours can be optionally used from 1st April 2004 and must be used in new installations from 1st April 2006. It should be recognised that installations starting on site prior to 1st April 2006 can be started and completed (regardless of the completion date) in "pre-harmonised" colours. However, they should not be mixed, i.e. a new installation started in this two year 'transitional' period should be in harmonised or pre-harmonised colours. This will be subject to cable availability (see Q&A section) at rear of this document.

## IMPLEMENTATION - TIMING

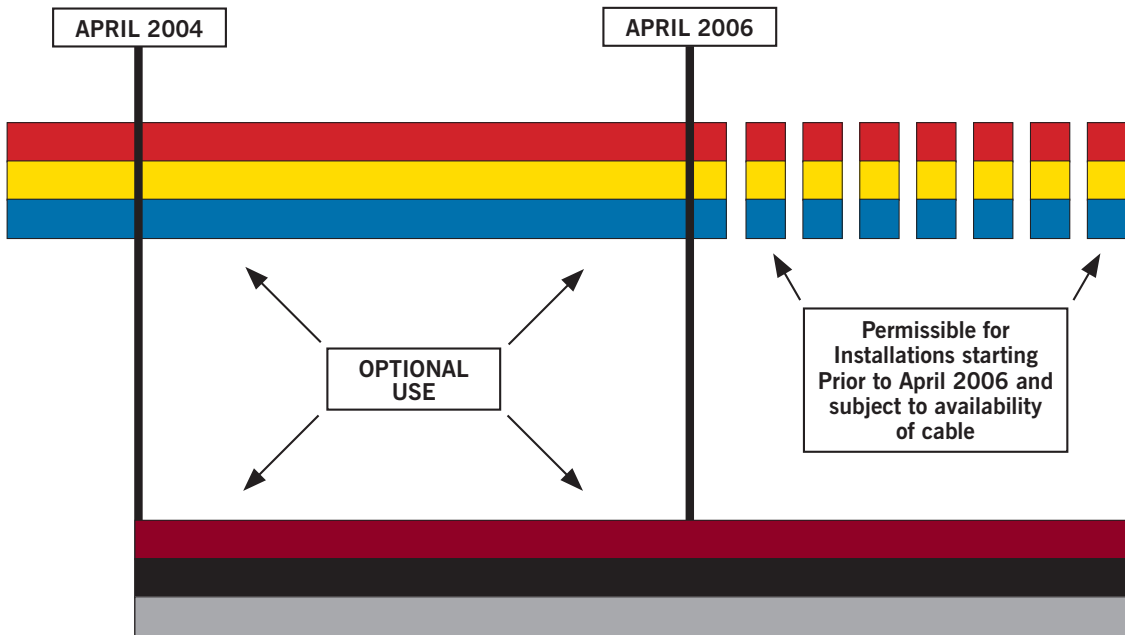

### NOTES:

Neutral or Earths not shown here for clarity. Timings also apply new to identification by lettering/numbers.  
New installations started between 1st April 2004 and 1st April 2006 should not be mixed.

## PRINCIPLE OF IDENTIFICATION (514-03)

It is important to understand the principle behind the drafting of the new Amendment No 2 as follows:

**Cable cores shall be identifiable at their terminations by either:**

**Colour, or  
Numbering/Lettering**

It is also stated that cores should *preferably* be identifiable throughout their length.

For many applications, coloured cables, either single or multiple core will be used and these cables are obviously identified throughout their length! However, in many other applications installers will need to make use of this regulation (514-03-01) see the diagram below for examples.

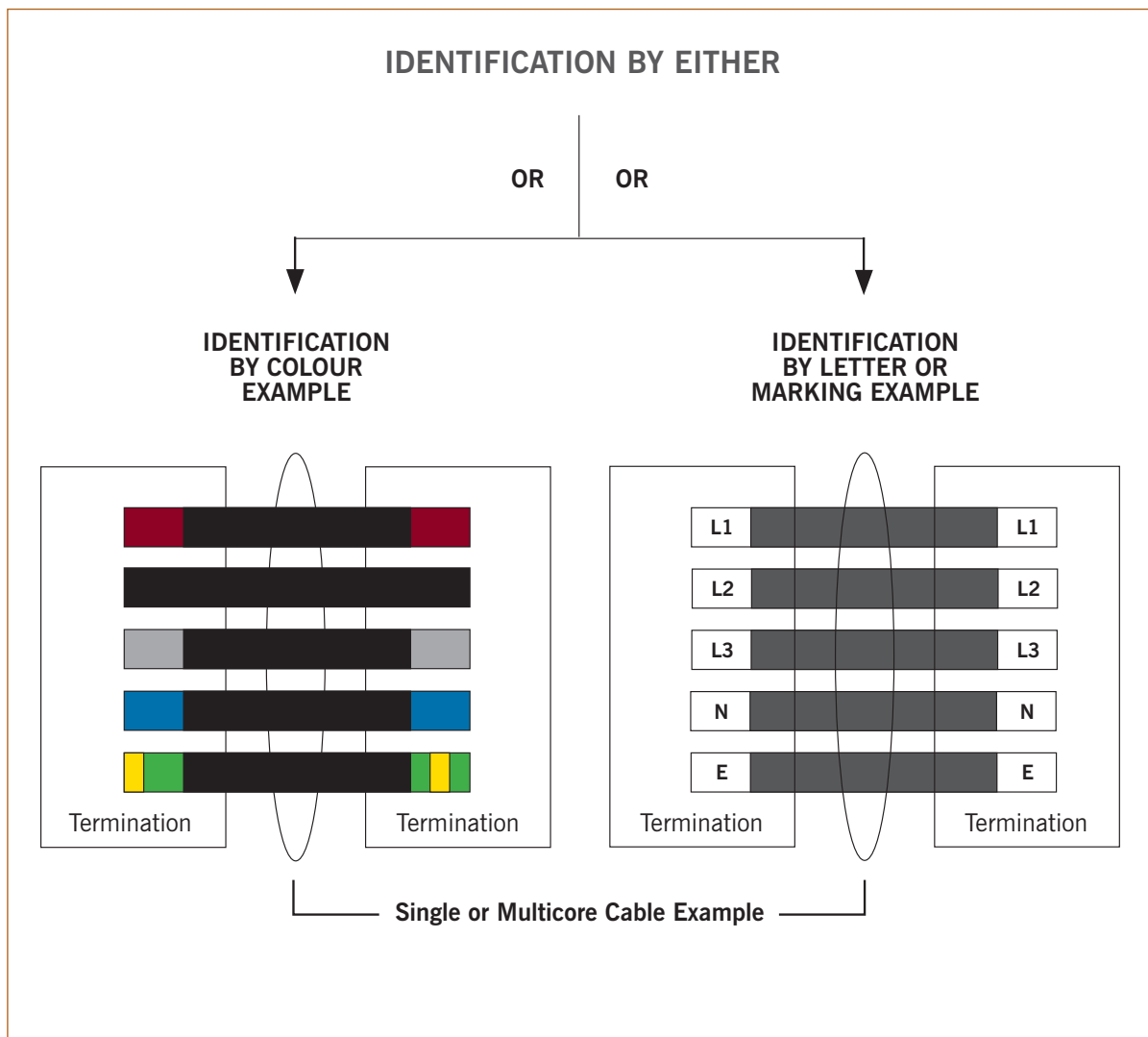

Common examples and applications where identification is only practiced at terminations include the following:

**Multi-Core Armoured Cables above five core**

**MICC Cables**

**Control Applications all wired in a single core**

**Applications where coloured cable is not available  
(alternator, generator and transformer connections)**

It is recognised that installers may wish to use any single cable colour, or combination thereof, and mark at terminations, and this is not considered a lesser option.

**NOTE:**

For green and yellow conductors in multicore cables, overmarking in another colour at terminations is permitted. This is prohibited for single core green and yellow conductors.

## IDENTIFICATION BY COLOUR (WHERE COLOUR IS USED)

Where colour is used to comply with the method of identification, a new Table 51 included within Amendment No 2, as below, gives the colours options.

<b>FUNCTION</b>	<b>ALPHA-NUMERIC</b>	<b>COLOUR</b>
Protective conductor Functional earthing conductor		Green-and-yellow Cream
<b>a.c. power circuit</b> <sup>(3)</sup> Phase of single-phase circuit Neutral of single- or three-phase circuit Phase 1 of three-phase circuit Phase 2 of three-phase circuit Phase 3 of three-phase circuit	L N L1 L2 L3	Brown Blue Brown Black Grey
<b>Two-wire unearthed d.c. power circuit</b> Positive of two-wire circuit Negative of two-wire circuit	L+ L-	Brown Grey
<b>Two-wire earthed d.c. power circuit</b> Positive (of negative earthed) circuit Negative (of negative earthed) circuit <sup>(4)</sup> Positive (of positive earthed) circuit <sup>(4)</sup> Negative (of positive earthed) circuit	L+ M M L-	Brown Blue Blue Grey
<b>Three-wire d.c. power circuit</b> Outer positive of two-wire circuit derived from three-wire system Outer negative of two-wire circuit derived from three-wire system Positive of three-wire circuit Mid-wire of three-wire circuit <sup>(1) (4)</sup> Negative of three-wire circuit	L+ L- L+ M L-	Brown Grey Brown Blue Grey
<b>Control circuits, ELV and other applications</b> Phase conductor	L	Brown, Black, Red Orange, yellow, Violet, Grey, White, Pink, Turquoise
Neutral or mid-wire <sup>(2)</sup>	N or M	Blue

**NOTES:**

(1) Only the middle wire of three-wire circuits may be earthed  
(2) An earthed PELV conductor is blue  
(3) Power circuits include lighting circuits  
(4) M identifies either the mid wire of a three wire d.c. circuit, or the earthed conductor of a two wire earthed dc circuit

Following the principles of the amendment, it should be stressed that the alpha-numerical column was added to Table 51 for reading purposes and if the colour option is used, these are not required.

## IDENTIFICATION BY NUMBERING OR LETTERING

Alternatively, the alpha-numeric identification of Table 51A can be applied or conductors can be numbered. Where conductors are numbered, to satisfy other parts of BS 7671, a suitable wiring diagram or equivalent will normally be required indicating the use of the numbers (unless there is no possibility of confusion); this is applicable to multicore cables (above five core) and the existing numbering system in these cable terminations packs will not be changed.

## ALTERATIONS, ADDITIONS & REFURBISHMENTS, ETC.

Subject to the availability of cable types (see Q&A in this document), an extension (alteration/addition) can be identified using either identification method (i.e. pre-harmonised or harmonised) between 1st April 2004 and 1st April 2006. After 1st April 2006 all new installations shall be to the harmonised colours or lettering/numbering in accordance with Amendment No 2.

Where pre-harmonised and harmonised cables are used in the same installation the following label must be applied at the relevant distribution boards or items of switchgear as appropriate.

### CAUTION

**This installation has wiring colours to two versions of BS7671. Great care should be taken before undertaking extension, alteration or repair that all conductors are correctly identified.**

It was recognised that this label does not need applying at all other points on a circuit - just at the point of the circuit most likely to be used for isolation in the future, most commonly the distribution boards and items of switchgear.

## INTERFACE MARKING

The new amendment requires that termination-over-marking is applied “except where there is no possibility of confusion” at interfaces (the interface is the joint between pre-harmonised and harmonised). In practice, the installer will need to take a view on this but a new Appendix 7 with Amendment No 2 states no marking is required for most single phase correctly coloured interfaces.

For 3 Phase, Appendix 7 suggests applying L1, L2, L3 and N at interfaces (again, where there is no possibility of confusion). This is required as detailed in the following examples 1, 2 and 3.

There are examples when interface marking will not be required but the decision is for the installer and if you are uncomfortable with interpretation it is recommended that you always apply the interface marking. However, some applications where interface marking may not normally be required are also detailed in the example diagrams.

# EXAMPLES OF COLOUR APPLICATIONS AND MARKING

## EXAMPLE 1

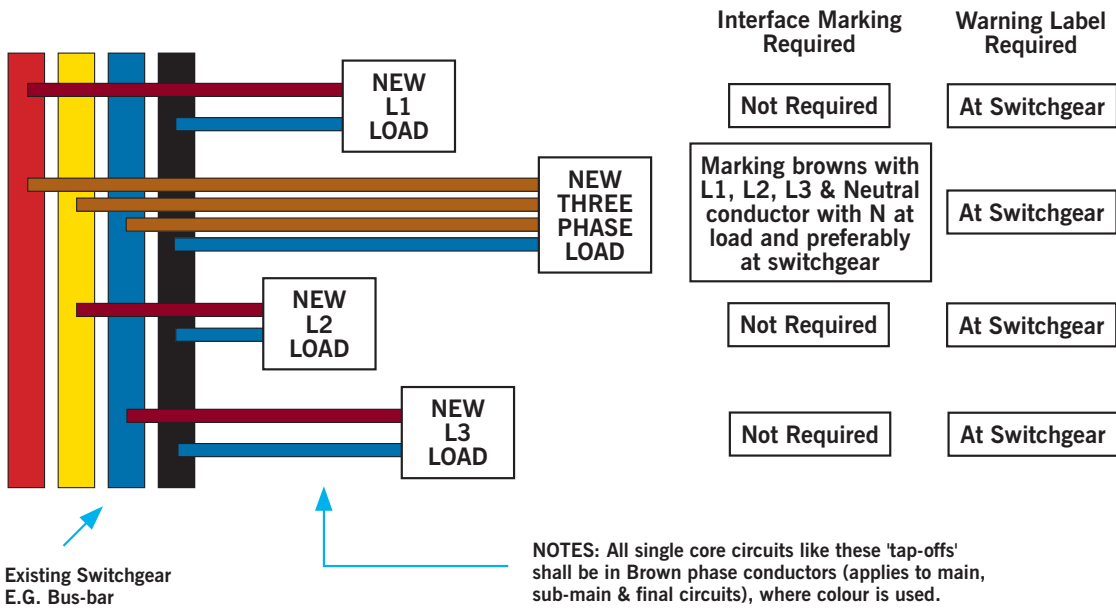

## EXAMPLE 2

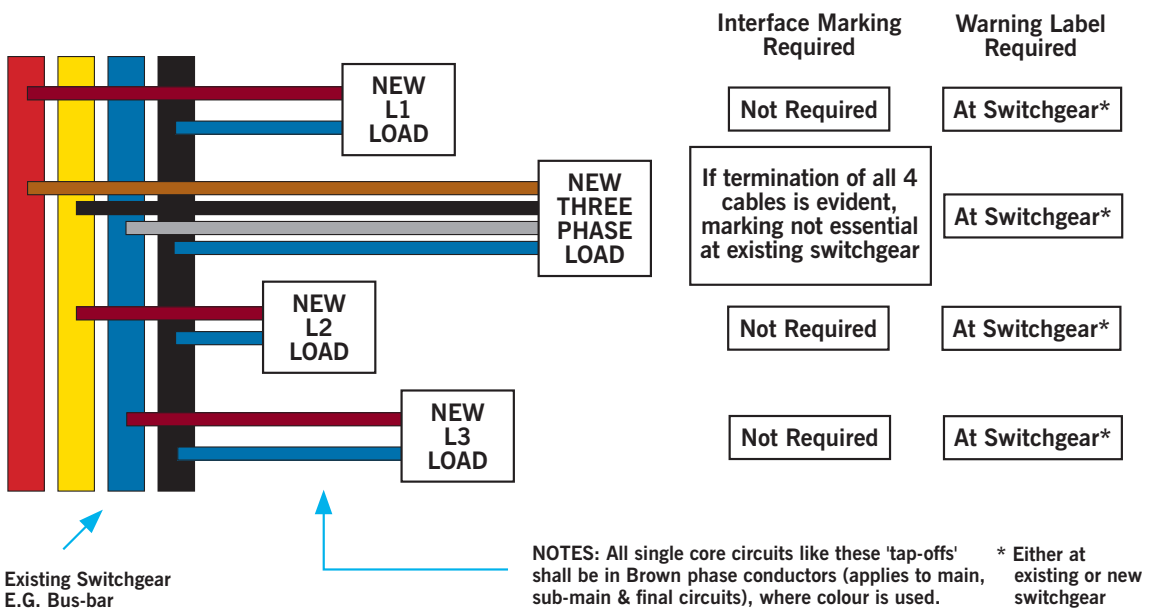

### EXAMPLE 3

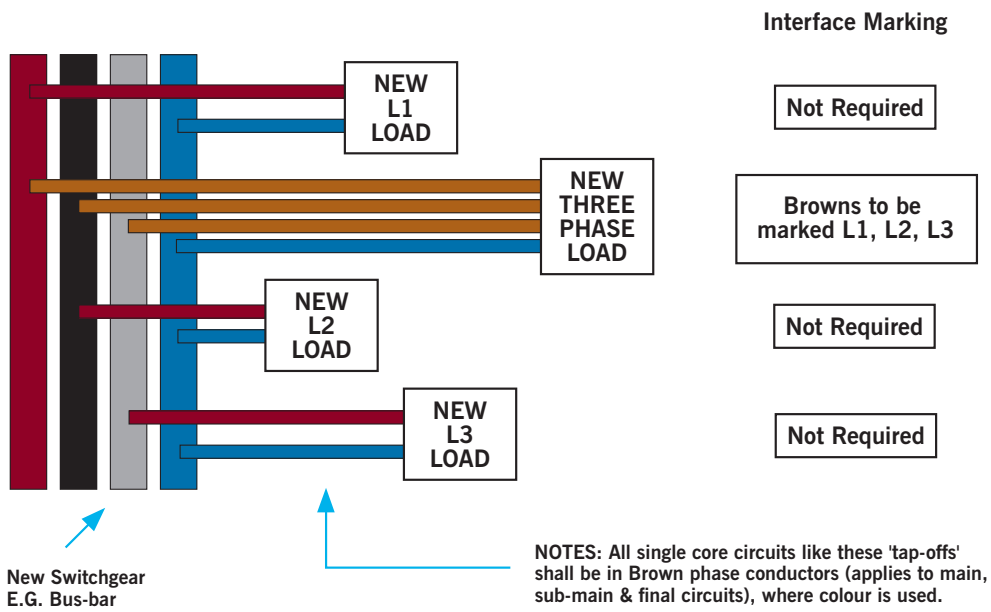

## OTHER MARKING:

### 2 CORE SWITCHWIRES

The blue, where used as a switched live, shall be marked with brown tape or the letter 'L' at terminations.

### 3 CORE 2 WAY/INTERMEDIATE

The black and grey cores in a 3 core cable shall be marked with brown tape or the letter 'L' at terminations.

### DC IDENTIFICATION

New DC colour or alpha numeric identification is given in Table 51 within Amendment No 2.

Again for extensions (alterations/applications), interface marking is required 'except where there is no possibility of confusion', refer to BS 7671 Appendix 7.

## BS 7671 CORE COLOURS - QUESTIONS AND ANSWERS

	QUESTION	ANSWER
1	Why is it necessary to change?	To have harmonised standard of cables within Europe and to harmonise with the existing flexible colours.
2	When will the change over take place?	From 1 April 2004, to be completed by 1 April 2006. Use from 2004 is optional.
3	What does the industry call the cables?	The new colours are known as 'Harmonised Core Colours'.
4	What are the new colours?	Nominally: Green & Yellow for protective conductors Blue for Neutral Brown for Phase or Brown/Black/Grey for 3 Phase (preferred - See 6).
5	What about Pyro or multi-cored armoured cables?	BS 7671 allows identification by either colour or lettering or numbering. Thus blacks (or any colour) with say 1-7 can be used (existing multi-core armoured), or they can be lettered L1, L2, L3, N, E etc.
6	Can other colours be used?	Yes - for phase conductors in special applications and control application, cables can be Brown, Black, Red, Orange, Yellow, Violet, Grey, White, Pink or Turquoise. No other marking is normally required. If these colours are used for a.c. power circuits the alpha-numeric marking of Table 51 should be applied at terminations.  Note: BS EN harmonised 2, 3, 4 and 5 core cables will only be available in the Brown phases or Brown Black Grey all with Blue neutrals and Green/Yellow CPCs.
7	Can old, pre-harmonised, colours be installed after 1 April 2006?	Yes - for projects started before 1 April 2006 can be finished in these colours, but cable availability may be a problem.
8	When will the new harmonised colours be available?	Most types of cable will be available from 1st April 2004 but this is a commercial topic and you should check with your supplier.
9	Can old pre-harmonised and new harmonised colours be used in the same installation?	Both types of cable should not be installed together in a new installation. For additions and alterations, where old and new cables exist "interface" marking is required and a label at switchgear (See 10).
10	What will happen at the interface in an existing building, which is being partially rewired after 1 April 2006?	New harmonised cables should be used with appropriate end marking of the interface terminations of the pre-harmonised cable. Marking on both old and harmonised cables is L1, L2, L3 and N. A label at the appropriate distribution board is required (see regulations). Alternatively to use up old stock, pre-harmonised cable can be used with appropriate termination interface and all other termination marking (as identification is then by marking and not colour).
11	Can sleeving at terminals be used for pre-harmonised cables to comply with the new colours?	Yes.
12	Will a pre-harmonised stocks of cables be available after 1 April 2004?	There will be supplies, but after 1 April 2004 most manufacturers will begin to cease manufacture of the pre-harmonised colours, unless there is a special order.
13	What will happen if the project is starting between April 2004 and April 2006, but may be completed after 2006?	The Designer and Installer will need to liaise carefully with the manufacturer and establish availability before choosing old or 'Harmonised' cables. It may prove that some 'mixing' is required with the appropriate interface marking.
14	Will manufacturers take back unused old, pre-harmonised, stock after 1 April 2004?	No.
15	Are individual company standards still allowed to be used, e.g. Shell?	Yes, this is a requirement in BS 7671 which is only a standard.

# ACTION AND RESPONSIBILITY OF DESIGNERS/CONTRACTORS, INSTALLERS AND INSPECTORS

All organisations or individuals should follow the following advice:

- i) Obtain a copy of the Amendment No 2 to BS 7671:2001
- ii) Inform all technical staff, engineering staff and operatives about the changes in the Amendment No 2. The depth of awareness training and instructions you provide will depend upon your staff, operatives and operations. It is advisable to record such instruction in personnel files.
- iii) Check your tenders, contracts and specifications documentation about the cables (pre-harmonised or harmonised) to be used for your various projects. You will need to liaise with clients, specifiers, cable manufacturers and suppliers. Be aware that there may be price variations depending upon uptake of the new colours from April 2004, hence it is important to discuss your requirements with your cable suppliers.

## Further information

Copies of this guide can be downloaded from the Association's website.

A copy of the Amendment No 2 to BS 7671:2001 - March 2004, is also available on our website -

[www.eca.co.uk/downloads](http://www.eca.co.uk/downloads)

Information will also be published on the IEE cable colour website -

[www.iee.org.uk/cablecolours](http://www.iee.org.uk/cablecolours)

Front cover cable image reproduced with permission by Pirelli Cables.



For additional information contact the  
ECA Technical Department at:



---

Representing the best in electrical  
engineering and building services

Electrical Contractors' Association  
ESCA House, 34 Palace Court, London, W2 4HY  
Tel 020 7313 4800 Fax 020 7221 7344  
Email [electricalcontractors@eca.co.uk](mailto:electricalcontractors@eca.co.uk) [www.eca.co.uk](http://www.eca.co.uk)