

- Ⓓ **Bedienungsanleitung  
Doppelschleifer**
- Ⓔ **Operating Instructions  
Double-Wheel Grinder/Sander**
- Ⓕ **Mode d'emploi  
de la meuleuse double**
- Ⓖ **Uputstva za upotrebu  
Dvostruka brusilica**
- Ⓘ **Istruzioni per l'uso  
Levigatrice doppia**
- Ⓚ **Betjeningsvejledning  
dobbeltsliber**
- Ⓒ **Návod k obsluze  
Dvojité bruska**
- Ⓜ **Használati utasítás  
Kettős köszörűgép**
- Ⓡ **Upute za uporabu  
dvostruke brusilice**
- Ⓢ **Návod na obsluhu  
Dvojité brúska**

①



Art.-Nr.: 44.125.50

I.-Nr.: 01017

BT-BG **150**

**Einhell**<sup>®</sup>

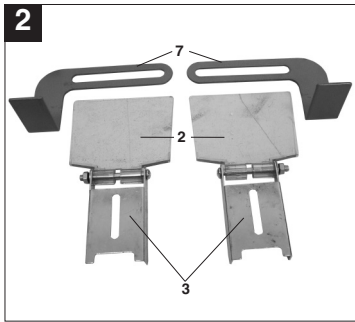
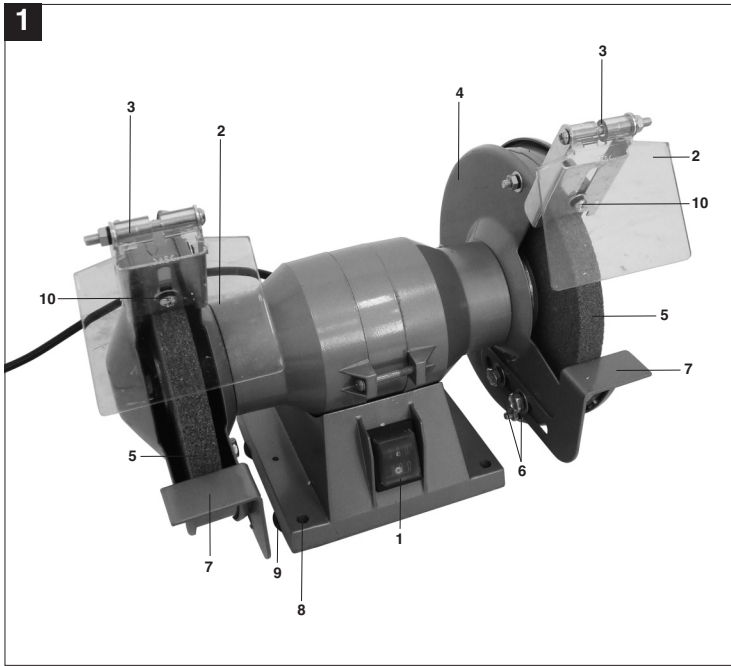

2

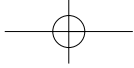
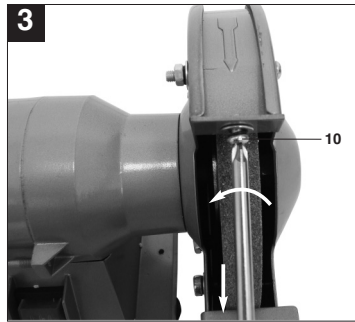

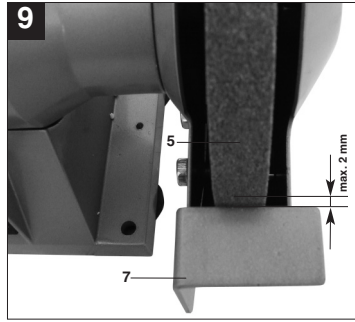
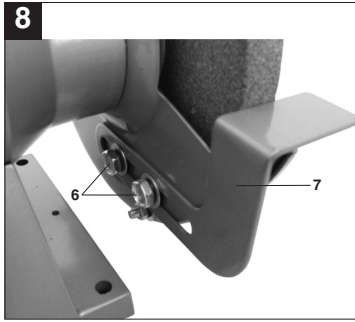
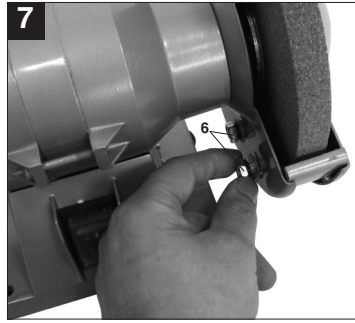
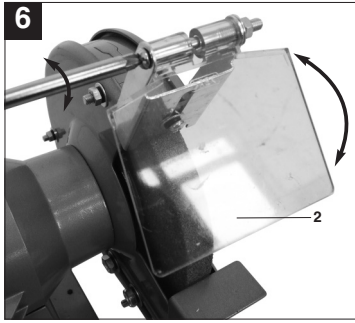
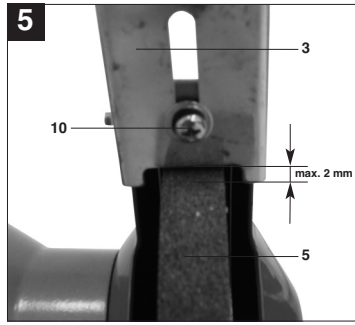
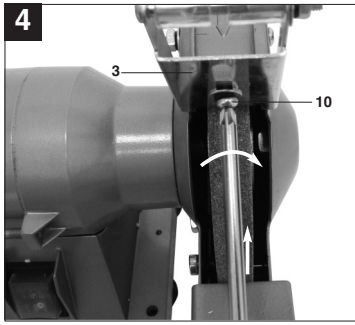

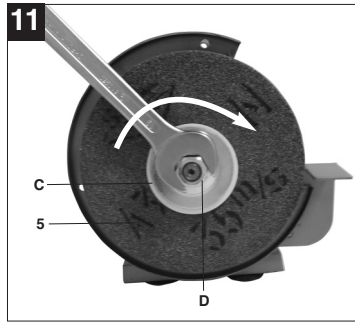
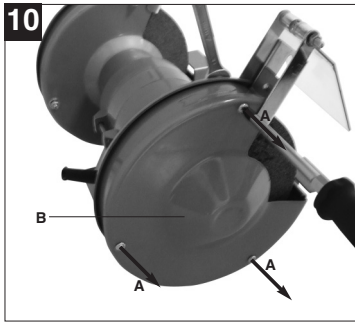

**GB****⚠ Important!**

When using equipment, a few safety precautions must be observed to avoid injuries and damage. Please read the complete operating manual with due care. Keep this manual in a safe place, so that the information is available at all times. If you give the equipment to any other person, give them these operating instructions as well.  
We accept no liability for damage or accidents which arise due to non-observance of these instructions and the safety information.

**1. Safety regulations**

The corresponding safety information can be found in the enclosed booklet.

**2. Layout (Fig. 1)**

- 1 ON/OFF switch
- 2 Safety window
- 3 Spark deflector
- 4 Safety hood
- 5 Grinding wheel
- 6 Workpiece support fastening screw
- 7 Workpiece support
- 8 Mounting holes
- 9 Foot
- 10 Spark deflector adjusting screw

**3. Proper use**

The double grinder is a multi-function tool for the rough and precision grinding of metals, plastics and other materials using a selection of grinding wheels.

The machine must only be used for its intended purpose! Even if the machine is used as intended, certain residual risk factors cannot be completely eliminated. The following hazards may arise in connection with the machine's construction and layout:

- Contact with the grinding wheel where it is not covered.
- Catapulting of parts from damaged grinding wheels.
- Catapulting of workpieces and parts of workpieces from the machine.
- Damage to hearing if ear-muffs are not used as necessary.

8

The machine is to be used only for its prescribed purpose. Any other use is deemed to be a case of misuse. The user / operator and not the manufacturer will be liable for any damage or injuries of any kind caused as a result of this.

Please note that our equipment has not been designed for use in commercial, trade or industrial applications. Our warranty will be voided if the machine is used in commercial, trade or industrial businesses or for equivalent purposes.

**4. Technical data**

Rated voltage:	230 V ~ 50 Hz
Power rating:	150 W S2 30 min
Idle speed $n_0$ :	2950 min <sup>-1</sup>
Grinding wheel diameter:	150 mm
Grinding wheel thickness:	16 mm
Grinding wheel hole diameter:	12.7 mm
Max. peripheral speed:	23.16 m/s
Weight:	6 kg

**Load factor:**

A load factor of S2 30 min (intermittent periodic duty) means that you may operate the motor continuously at its nominal power level (150 W) for no longer than the time stipulated on the specifications label (30 minutes ON period). If you fail to observe this time limit the motor will overheat. During the OFF period the motor will cool again to its starting temperature.

**Noise emission levels**

The noise emitted by this saw is measured in accordance with EN ISO 3744; EN ISO 11201  
The noise at the workplace may exceed 85 db (A).  
The user will require noise protection measures if this is the case. (Wear ear-muffs!)

No-Load operation	
Sound pressure level $L_{pA}$	62 dB
Sound power level $L_{WA}$	75 dB

## 5. Before starting the equipment

**Pull the power plug before doing any maintenance or assembly work on the equipment.**

- The machine must be set up so that it stands firmly, i.e. it must be securely screwed to a work bench or similar.
- All covers and safety devices have to be properly fitted before the machine is switched on.
- It must be possible for the grinding wheel to run freely.
- Check that the voltage on the rating plate is the same as your supply voltage before you connect the machine to the power supply.

### 5.1 Fitting the spark reflector (Fig. 3-4 / Item 3)

- Fit the spark reflector (3) to the double wheel grinder/sander using the adjusting screw (10).

### 5.2 Adjusting the spark reflector (Fig. 4-6 / Item 3)

- Adjust the spark deflector (3) using the adjusting screw (10) so that the distance between the dry grinding wheel (5) and the spark deflector (3) is as small as possible and certainly does not exceed 2 mm.
- Adjust the spark deflector (3) periodically to compensate for wear on the wheel.

### 5.3 Fitting the workpiece supports (Fig. 7-8 / Item 7)

- Undo the fastening screws (6). Secure the workpiece supports (7) to the double wheel grinder/sander using the fastening screws (6).

### 5.4 Adjusting the workpiece supports (Fig. 8-9 / Item 7)

- Adjust the workpiece supports (7) using the fastening screws (6) so that the distance between the dry grinding wheel (5) and the workpiece support (7) is as small as possible and certainly does not exceed 2 mm.
- Adjust the workpiece supports (7) periodically to compensate for wear on the dry grinding wheel.

### 5.5 Changing the grinding wheel (Figs. 10-11)

Remove the 3 screws (A) holding the side section of the safety hood (B) and remove the safety hood. Undo the nut (D) (**Important: The left grinding wheel is fastened with a left-handed thread and the right grinding wheel with a right-handed thread**), by holding the nut of the grinding wheel mount on the opposite side. Remove the flange (C).

and replace the grinding wheel (5). To assemble, proceed in reverse order.

## 6. Operation

### 6.1 ON/OFF switch (1)

To switch on the equipment set the On/Off switch (1) to position 1. Move the ON/OFF switch (1) to position 0 to switch off the equipment.

After switching on the equipment wait for the equipment to reach its maximum speed of rotation before commencing with the sanding/grinding work.

### 6.2 Grinding

- We recommend that you use the fine-grained grinding wheel for fine sanding/grinding work and the coarse-grained grinding wheel for coarse sanding/grinding work.
- Place the workpiece onto the workpiece support (7) and slowly guide the workpiece towards the grinding wheel (5) at the desired angle to the point where workpiece and grinding wheel make contact.
- Move the workpiece slightly back and forth to produce an optimal grinding result. This way the grinding wheel (5) is evenly worn. Allow the workpiece cool every now and then.

## 7. Cleaning, maintenance and ordering of spare parts

Always pull out the mains power plug before starting any cleaning work.

### 7.1 Cleaning

- Keep all safety devices, air vents and the motor housing free of dirt and dust as far as possible. Wipe the equipment with a clean cloth or blow it with compressed air at low pressure.
- We recommend that you clean the device immediately each time you have finished using it.
- Clean the equipment regularly with a moist cloth and some soft soap. Do not use cleaning agents or solvents; these could attack the plastic parts of the equipment. Ensure that no water can seep into the device.

### 7.2 Maintenance

- There are no parts inside the equipment which require additional maintenance.

**GB**

**7.3 Ordering replacement parts:**

Please quote the following data when ordering replacement parts:

- Type of machine
- Article number of the machine
- Identification number of the machine
- Replacement part number of the part required

For our latest prices and information please go to [www.isc-gmbh.info](http://www.isc-gmbh.info)

**8. Disposal and recycling**

The unit is supplied in packaging to prevent its being damaged in transit. This packaging is raw material and can therefore be reused or can be returned to the raw material system.

The unit and its accessories are made of various types of material, such as metal and plastic. Defective components must be disposed of as special waste. Ask your dealer or your local council.



**Konformitätserklärung**

ISC-GmbH · Eschenstraße 6 · D-94405 Landau/Isar

erklärt folgende Konformität gemäß EU-Richtlinie und Normen für Artikel  
 declares conformity with the EU Directive and standards marked below for the article  
 déclare la conformité suivante selon la directive CE et les normes concernant l'article  
 verklaart de volgende conformiteit in overeenstemming met de EU-richtlijn en normen voor het artikel  
 declara la siguiente conformidad a tenor de la directiva y normas de la UE para el artículo  
 declara a seguinte conformidade de acordo com a directiva CE e normas para o artigo  
 förklarar följande överensstämmelse enl. EU-direktiv och standarder för artikeln  
 ilmoittaa seuraavaa Euroopan unionin direktiivien ja normien mukaista yhdenmukaisuutta tuotteelle  
 erklærer herved følgende samsvar med EU-direktiv og standarder for artikkelen  
 заявляєт о соответствии товара следующим директивам и нормам ЕС  
 izjavljuje sljedeću uskladenost s odredbama i normama EU za artikl.  
 declară următoarea conformitate cu linia directoare CE și normele valabile pentru articolul.  
 ürdin ile ilgili olarak AB Yönetmeliğleri ve Normları gereğince aşağıdaki uygunluk açıkları masını sunar.  
 δηλώνει την ακόλουθη συμφωνία σύμφωνα με την Οδηγία ΕΕ και τα πρότυπα για το προϊόν

dichiara la seguente conformità secondo la direttiva UE e le norme per l'articolo  
 atesteterer følgende overensstemmelse i henhold til EU-direktiv og standarder for produkt  
 prohlašuje následující shodu podle směrnice EU a norm pro výrobek.  
 a következő konformitást jelenti ki a termékerekre vonatkozó EU-irányvonalak és normák szerint  
 pojasnjuje sledečo skladnost po smernici EU in normah za artikel.  
 deklaruje zgodnost wymienionego poniżej artykułu z następującymi normami na podstawie dyrektywy WE.  
 vydáva nasledujúce prehlásenie o zhode podľa smernice EU a noriem pre výrobok.  
 декларира следното съответствие съгласно директивите и нормите на ЕС за продукта.  
 заявляе про відповідність згідно з Директивою СС та стандартами, чинними для даного товару  
 deklareerib vastavuse järgnevatele EL direktiivi dele ja normidele  
 deklaruoja atitikti pagal ES direktyvas ir normas straipsniui  
 izjavljuje sledeći konformitet u skladu s odredbom EZ i normama za artikl  
 Atbilstības sertifikāts apliecina zemāk minēto preču atbilstību ES direktīvam un standartiem  
 Samræmslýfinging staðfestir eftirfarandi samræmi samkvæmt reglum Evrópubandalagsins og stöðlum fyrir vörur

**Doppelschleifer BT-BG 150**

<input checked="" type="checkbox"/> 98/37/EC	<input type="checkbox"/> 87/404/EEC
<input checked="" type="checkbox"/> 2006/95/EC	<input type="checkbox"/> R&TTED 1999/5/EC
<input type="checkbox"/> 97/23/EC	<input type="checkbox"/> 2000/14/EG_2005/88/EC:
<input checked="" type="checkbox"/> 2004/108/EC	<input type="checkbox"/> 95/54/EC:
<input type="checkbox"/> 90/396/EEC	<input type="checkbox"/> 97/68/EC:
<input type="checkbox"/> 89/686/EEC	

EN 61029-1; EN 61029-2-4; EN 55014-1; EN 55014-2; EN 61000-3-2; EN 61000-3-3

Landau/Isar, den 21.01.2008

*[Signature]*  
 Weichselgartner  
 General-Manager

*[Signature]*  
 Baumstark  
 Product-Management

Art.-Nr.: 44.125.50 I.-Nr.: 01017 Archivierung: 4412550-32-4155050-07  
 Subject to change without notice



⑤ Nur für EU-Länder

Werfen Sie Elektrowerkzeuge nicht in den Hausmüll!

Gemäß europäischer Richtlinie 2002/96/EG über Elektro- und Elektronik-Altgeräte und Umsetzung in nationales Recht müssen verbrauchte Elektrowerkzeuge getrennt gesammelt werden und einer umweltgerechten Wiederverwertung zugeführt werden.

Recycling-Alternative zur Rücksendeaufforderung:

Der Eigentümer des Elektrogerätes ist alternativ anstelle Rücksendung zur Mitwirkung bei der sachgerechten Verwertung im Falle der Eigentumsaufgabe verpflichtet. Das Altgerät kann hierfür auch einer Rücknahmestelle überlassen werden, die eine Beseitigung im Sinne der nationalen Kreislaufwirtschafts- und Abfallgesetze durchführt. Nicht betroffen sind den Altgeräten beigefügte Zubehörteile und Hilfsmittel ohne Elektrobestandteile.

⑥ For EU countries only

Never place any electric tools in your household refuse.

To comply with European Directive 2002/96/EC concerning old electric and electronic equipment and its implementation in national laws, old electric tools have to be separated from other waste and disposed of in an environment-friendly fashion, e.g. by taking to a recycling depot.

Recycling alternative to the demand to return electrical devices:

As an alternative to returning the electrical device, the owner is obliged to cooperate in ensuring that the device is properly recycled if ownership is relinquished. This can also be done by handing over the used device to a returns center, which will dispose of it in accordance with national commercial and industrial waste management legislation. This does not apply to the accessories and auxiliary equipment without any electrical components which are included with the used device.

⑦ Uniquement pour les pays de l'Union Européenne

Ne jetez pas les outils électriques dans les ordures ménagères.

Selon la norme européenne 2002/96/CE relative aux appareils électriques et systèmes électroniques usés et selon son application dans le droit national, les outils électriques usés doivent être récoltés à part et apportés à un recyclage respectueux de l'environnement.

Possibilité de recyclage en alternative à la demande de renvoi :

Le propriétaire de l'appareil électrique est obligé, en guise d'alternative à un envoi en retour, à contribuer à un recyclage effectué dans les règles de l'art en cas de cessation de la propriété. L'ancien appareil peut être remis à un point de collecte dans ce but. Cet organisme devra éliminer dans le sens de la Loi sur le cycle des matières et les déchets. Ne sont pas concernés les accessoires et ressources fournies sans composants électroniques.

# **GUARANTEE CERTIFICATE**

Dear Customer,

All of our products undergo strict quality checks to ensure that they reach you in perfect condition. In the unlikely event that your device develops a fault, please contact our service department at the address shown on this guarantee card. Of course, if you would prefer to call us then we are also happy to offer our assistance under the service number printed below. Please note the following terms under which guarantee claims can be made:

1. These guarantee terms cover additional guarantee rights and do not affect your statutory warranty rights. We do not charge you for this guarantee.
2. Our guarantee only covers problems caused by material or manufacturing defects, and it is restricted to the rectification of these defects or replacement of the device. Please note that our devices have not been designed for use in commercial, trade or industrial applications. Consequently, the guarantee is invalidated if the equipment is used in commercial, trade or industrial applications or for other equivalent activities. The following are also excluded from our guarantee: compensation for transport damage, damage caused by failure to comply with the installation/assembly instructions or damage caused by unprofessional installation, failure to comply with the operating instructions (e.g. connection to the wrong mains voltage or current type), misuse or inappropriate use (such as overloading of the device or use of non-approved tools or accessories), failure to comply with the maintenance and safety regulations, ingress of foreign bodies into the device (e.g. sand, stones or dust), effects of force or external influences (e.g. damage caused by the device being dropped) and normal wear resulting from proper operation of the device.  
  
The guarantee is rendered null and void if any attempt is made to tamper with the device.
3. The guarantee is valid for a period of 2 years starting from the purchase date of the device. Guarantee claims should be submitted before the end of the guarantee period within two weeks of the defect being noticed. No guarantee claims will be accepted after the end of the guarantee period. The original guarantee period remains applicable to the device even if repairs are carried out or parts are replaced. In such cases, the work performed or parts fitted will not result in an extension of the guarantee period, and no new guarantee will become active for the work performed or parts fitted. This also applies when an on-site service is used.
4. In order to assert your guarantee claim, please send your defective device postage-free to the address shown below. Please enclose either the original or a copy of your sales receipt or another dated proof of purchase. Please keep your sales receipt in a safe place, as it is your proof of purchase. It would help us if you could describe the nature of the problem in as much detail as possible. If the defect is covered by our guarantee then your device will either be repaired immediately and returned to you, or we will send you a new device.

Of course, we are also happy offer a chargeable repair service for any defects which are not covered by the scope of this guarantee or for units which are no longer covered. To take advantage of this service, please send the device to our service address.