



# Electronic Frost THERMOSTAT

Model No. **FT100**

## Features

- ☞ Tamper Proof
- ☞ Large Dial
- ☞ Temperature range between  $-10^{\circ}\text{C}$  and  $20^{\circ}\text{C}$
- ☞ Simple to use
- ☞ Voltage between 220/240V
- ☞ LED Indicator to show heat called for

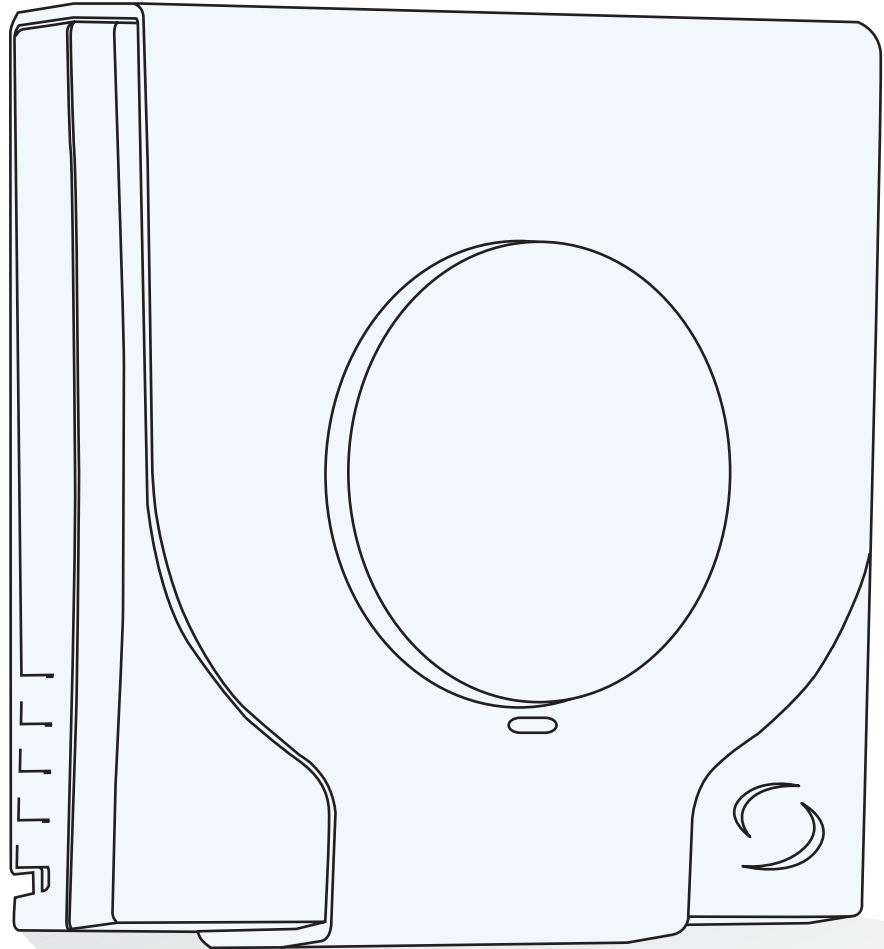

☞ User Friendly

The FT100 is a mains voltage thermostat with a key function of protecting a property from the frost. On the fall of temperature the FT100 can switch a pump, Zone Valve and boiler, thus protecting the house from freezing pipes. There is a protective cover to prevent tampering of the FT100, which allows the user peace of mind.

Heating Controls



CONTROL TECHNOLOGY FOR LIFE

[www.salus-tech.com](http://www.salus-tech.com)

# Electronic Frost THERMOSTAT

Model No. **FT100**

## Installation

The FT100 can be either surface mounted or flush switch box mounted. The standard industry back plate provides ease of wiring. The back plate has holes to suit switch boxes and provision for surface wiring.

The FT100 must be located where it would not be subjected to extraneous heat gain/loss (such as in direct sunlight or draughts).

## Specification

Switch Rating	: 230V/50Hz/3A
Switch Type	: Single pole, single throw (SPST)
Power Supply	: 230V/50Hz
Operating Temperature	: 0°C - 50°C
Temperature Setting Range	: -10°C - 20°C
Storage Conditions	: -20°C - 55°C to 90% RH/non condensing
Temperature Control Accuracy	: +/- 1°C at 25°C
Operating Humidity	: 0 to 90% RH/non condensing
Agency Approval	: CE

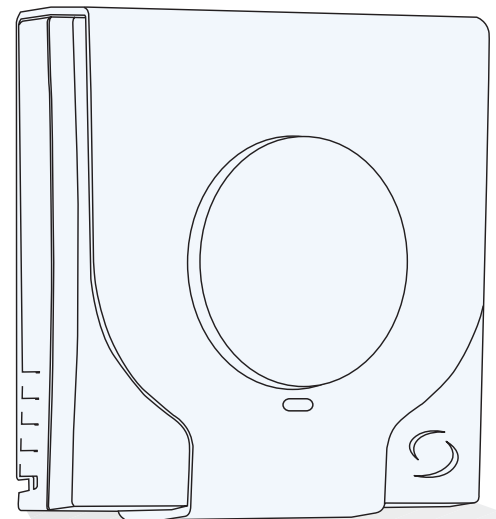

Heating Controls

## Dimension (mm)

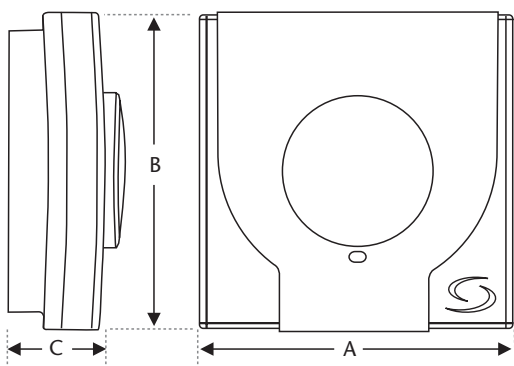

A	B	C
95	95	43

## Wiring Diagram

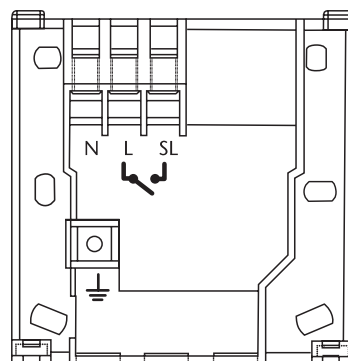

**SALUS**<sup>®</sup>  
TECHNOLOGY GROUP

Sales +44 (0) 8700 766900 Technical +44 (0) 8700 766902 Customer Services +44 (0) 8700 766902

Salus Controls plc Enterprise Park, Bala, Gwynedd, LL23 7NL Regional offices, England & Scotland.

Maintaining a policy of continual product development Salus Controls Plc. reserve the right to change specification, design and materials of products listed in this brochure without prior notice.

Web: [www.salus-tech.com](http://www.salus-tech.com) Email: [sales@salus-tech.com](mailto:sales@salus-tech.com)